

AFFETTACARNE VERTICALE
VERTICAL MEAT SLICERS / TRANCHEVIANDES VERTICAUX /
SENKRECHTFLEISCHSCHNEIDEMASCHINEN

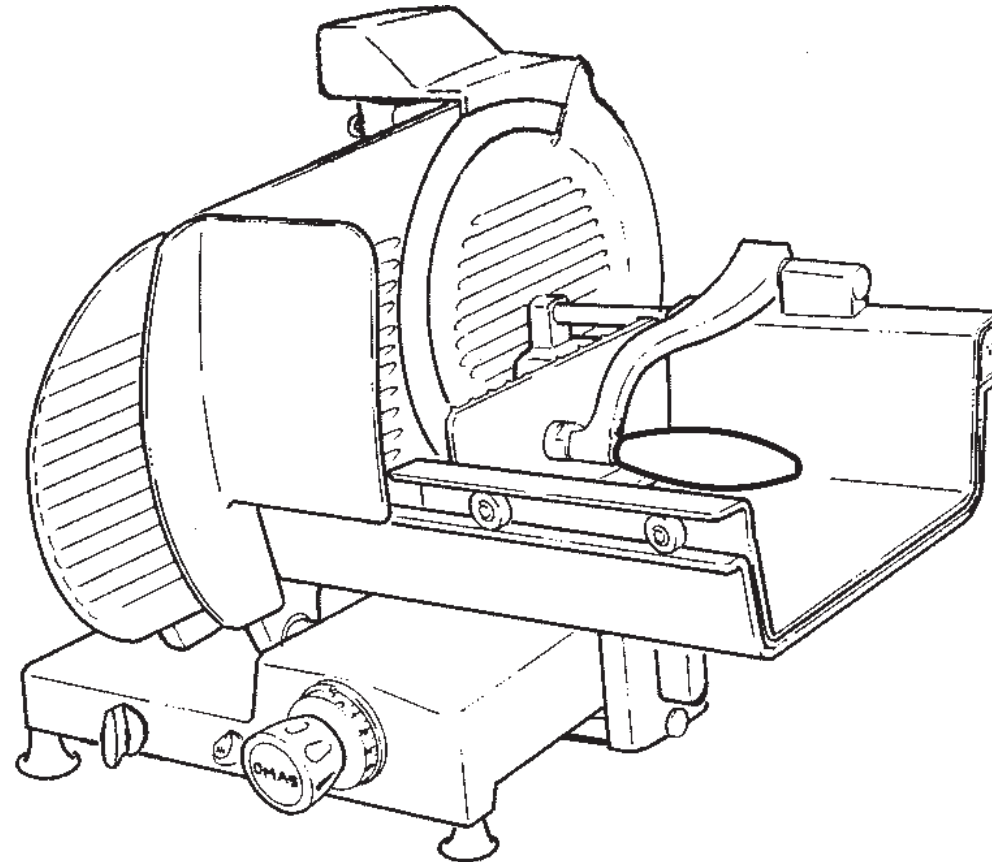

H 300
H 330

OMAS
Food machinery

OMAS s.p.a.
Via 4 Novembre 6
21040 OGGIONA S.STEFANO (VA) ITALY
Tel.0331/214311 - Fax.0331/214350

PEZZI DI RICAMBIO
SPARE PARTS LIST

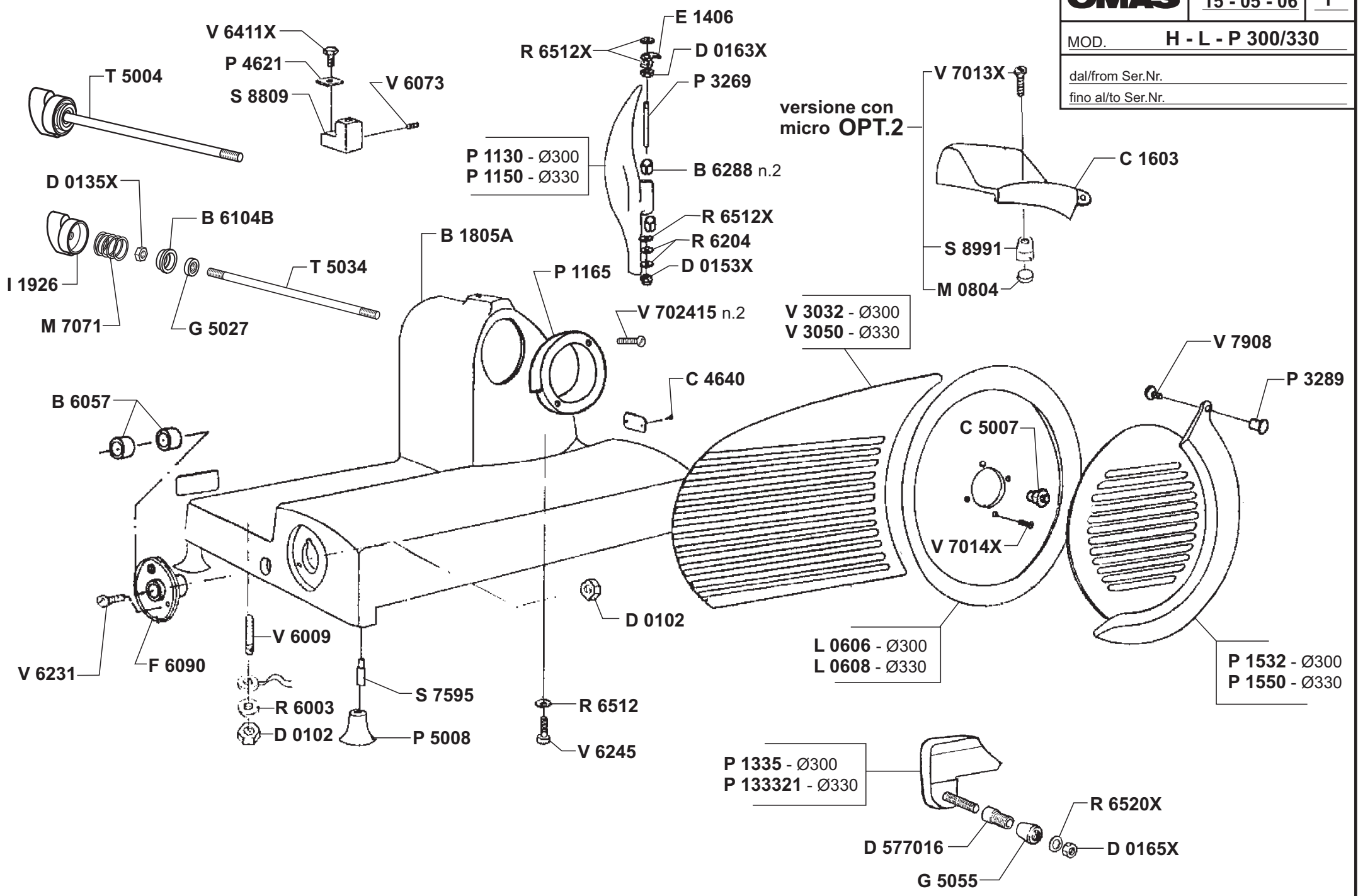

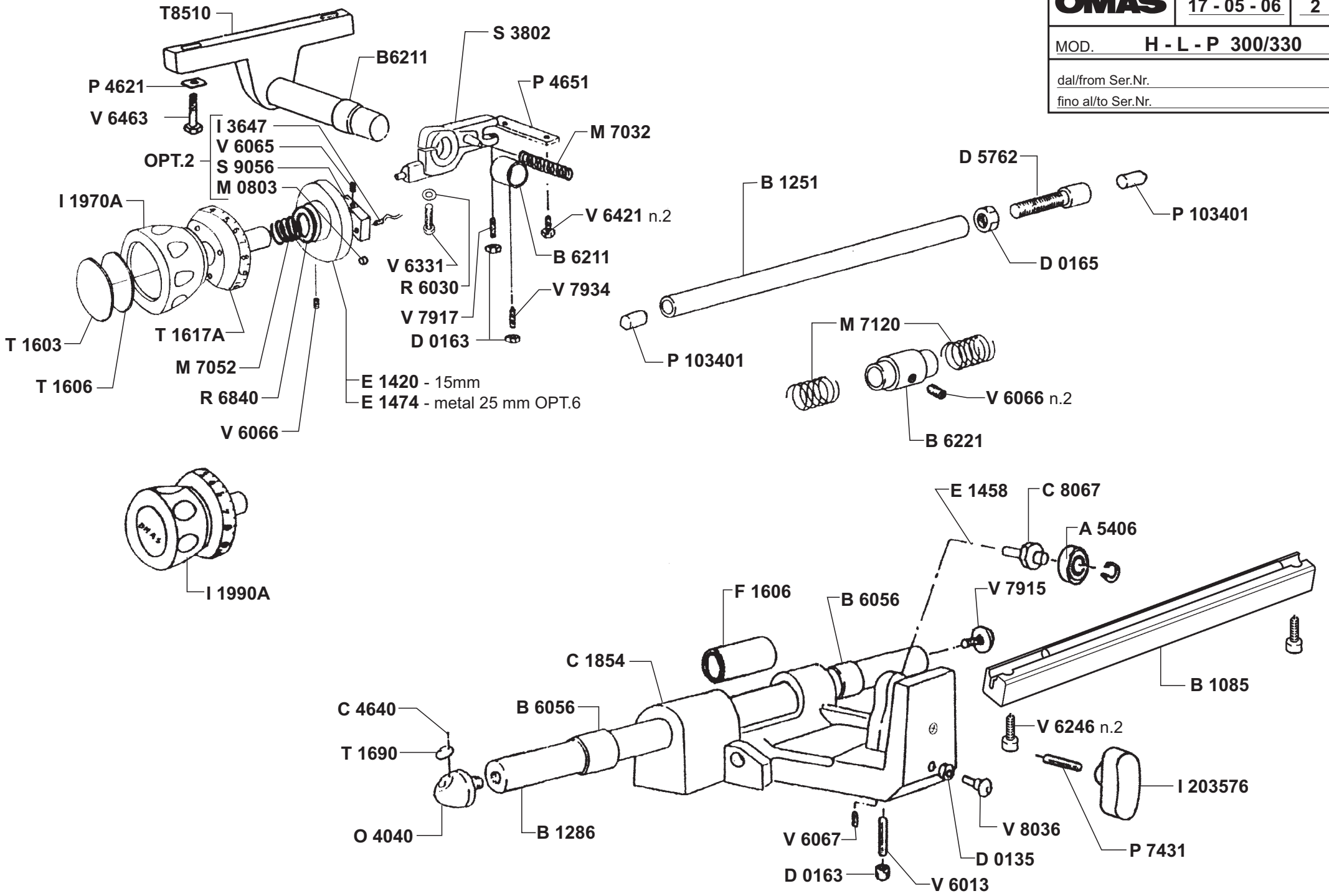

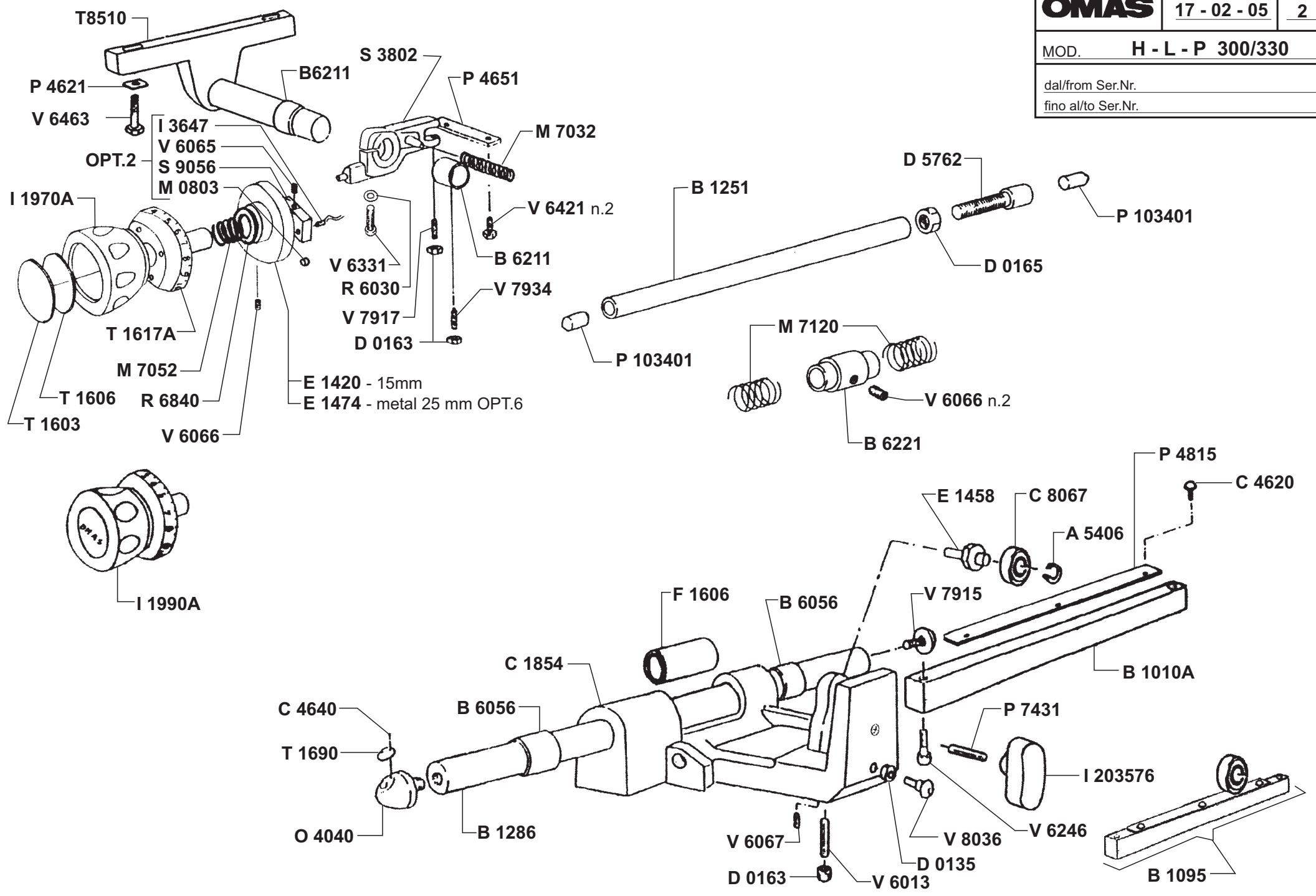

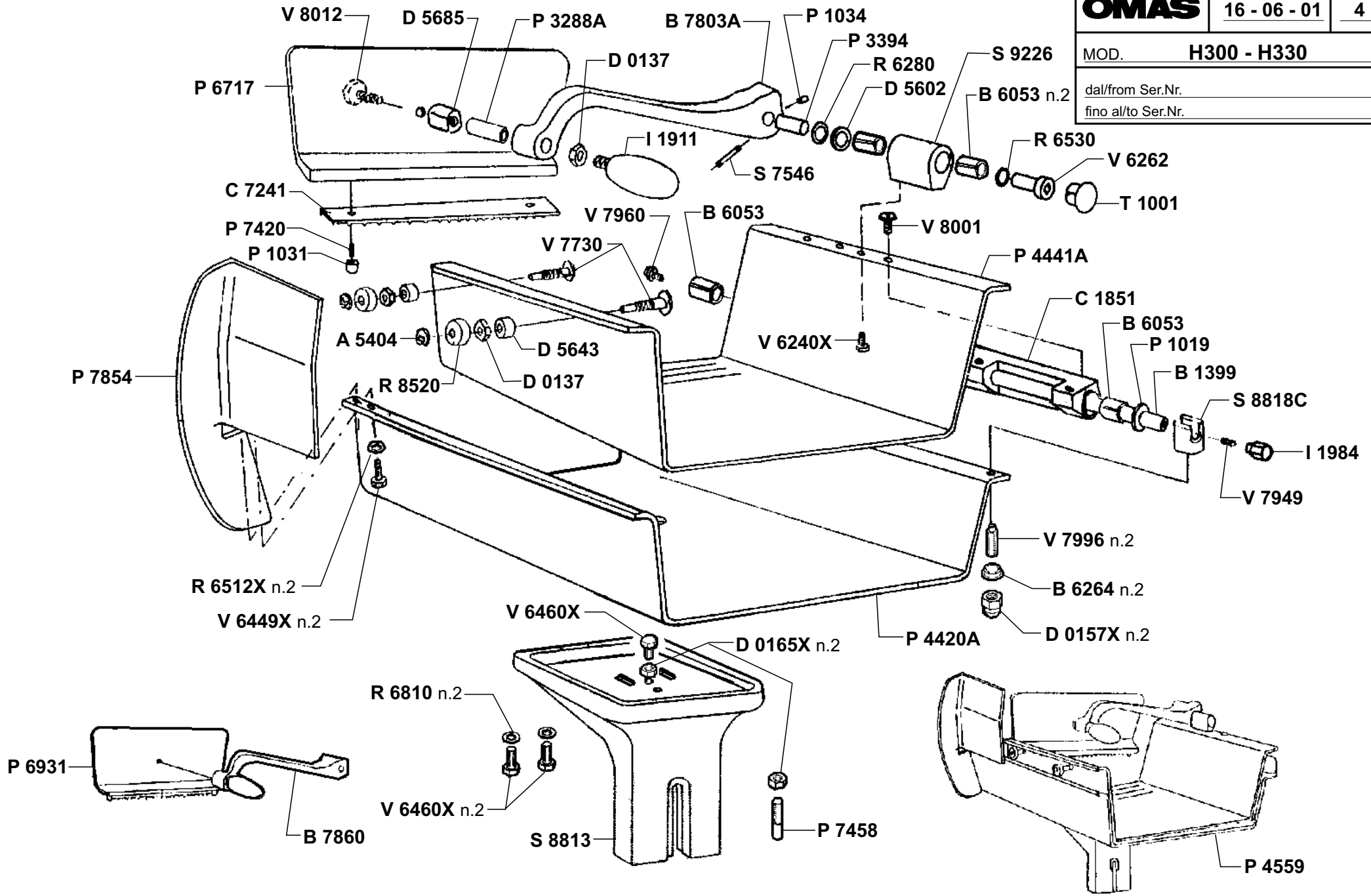

MOTORE MONOFASE

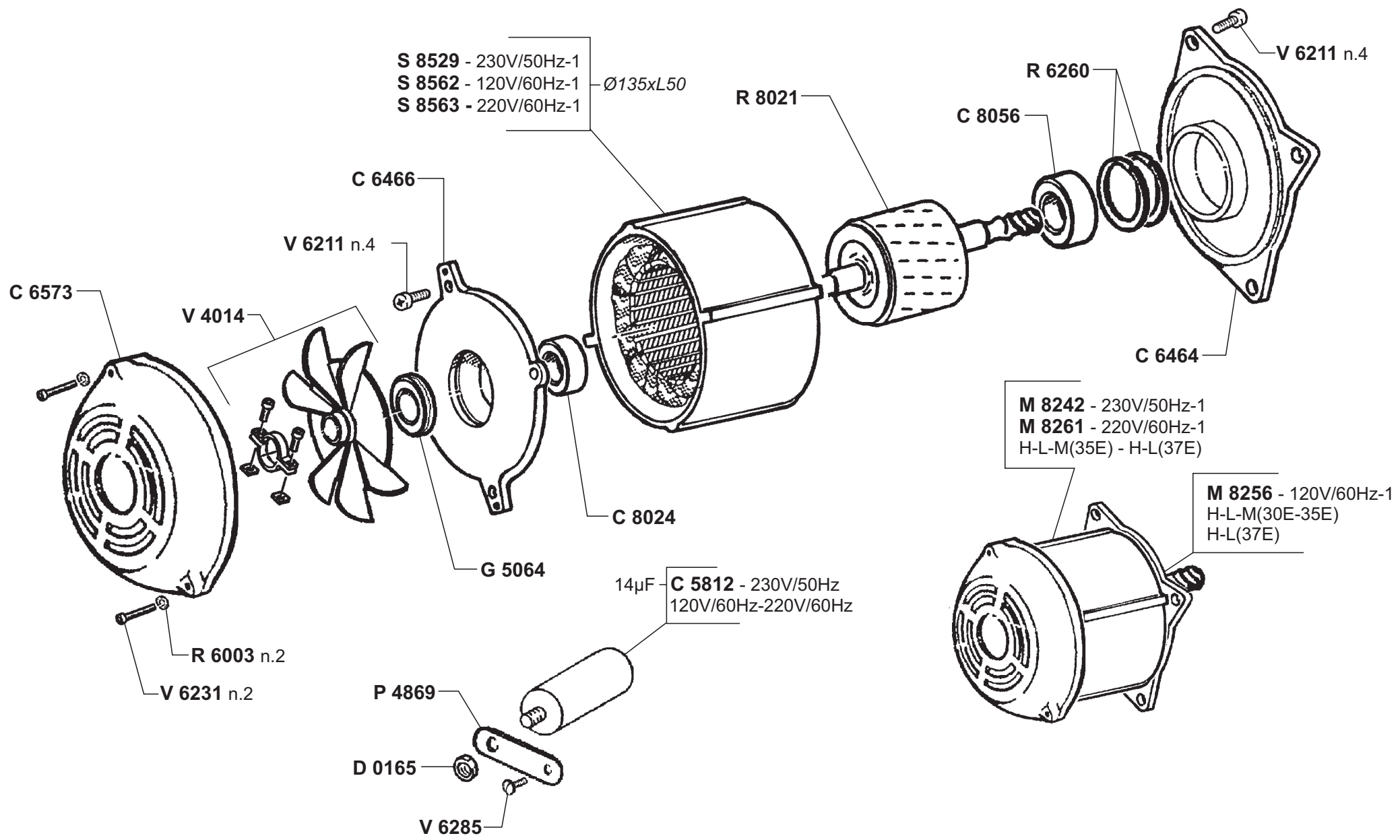

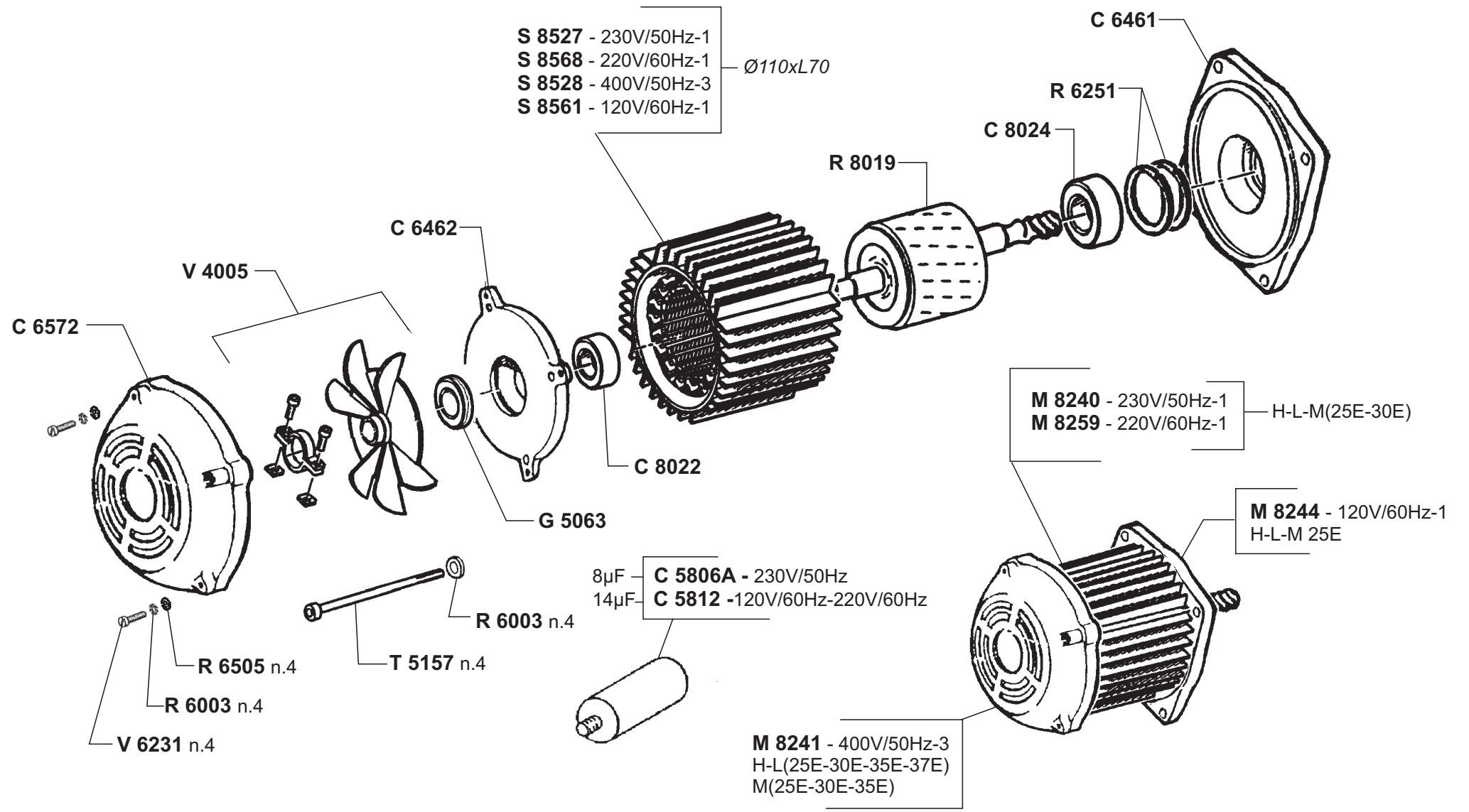

MOTORI

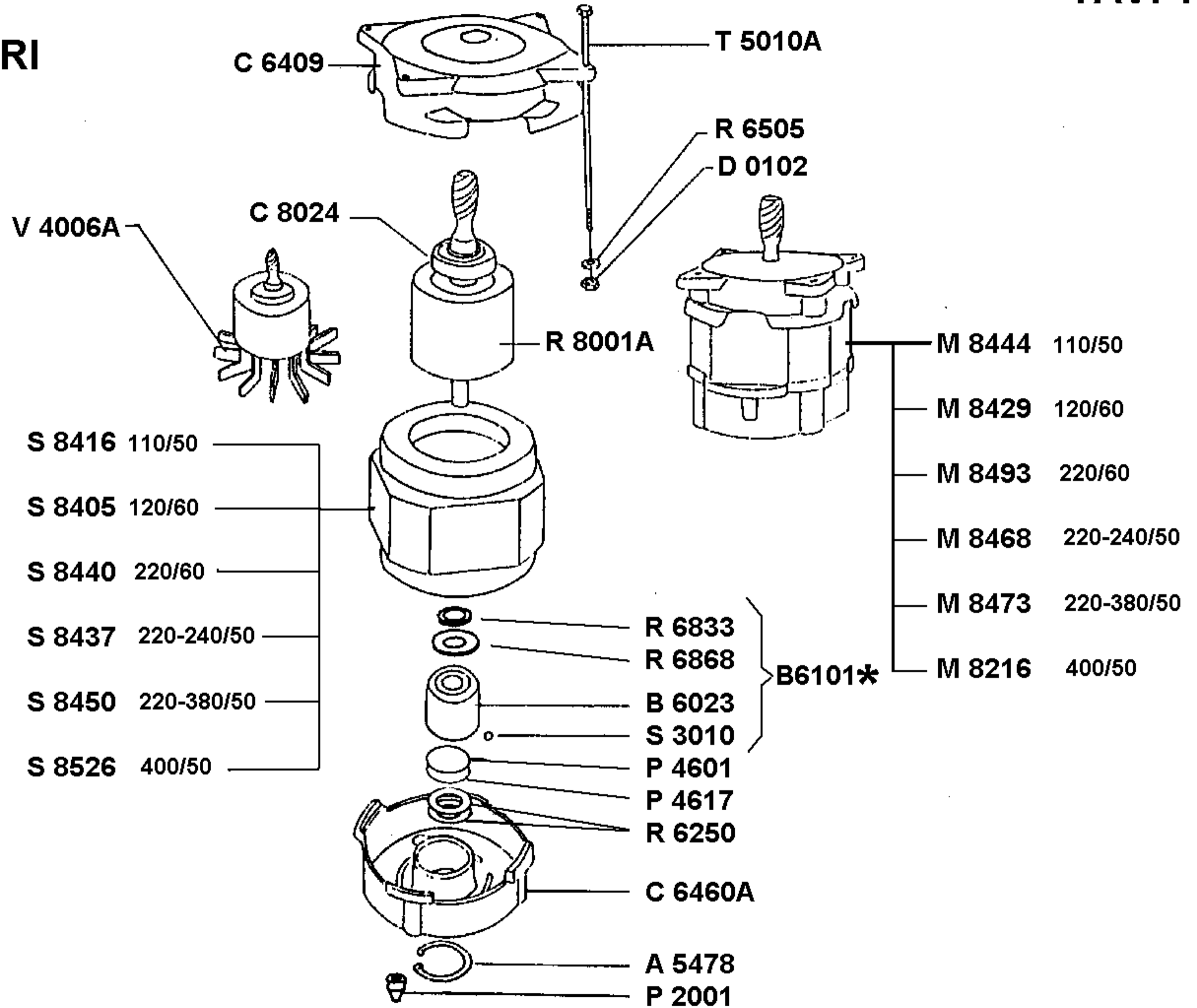

AFFILATOIO

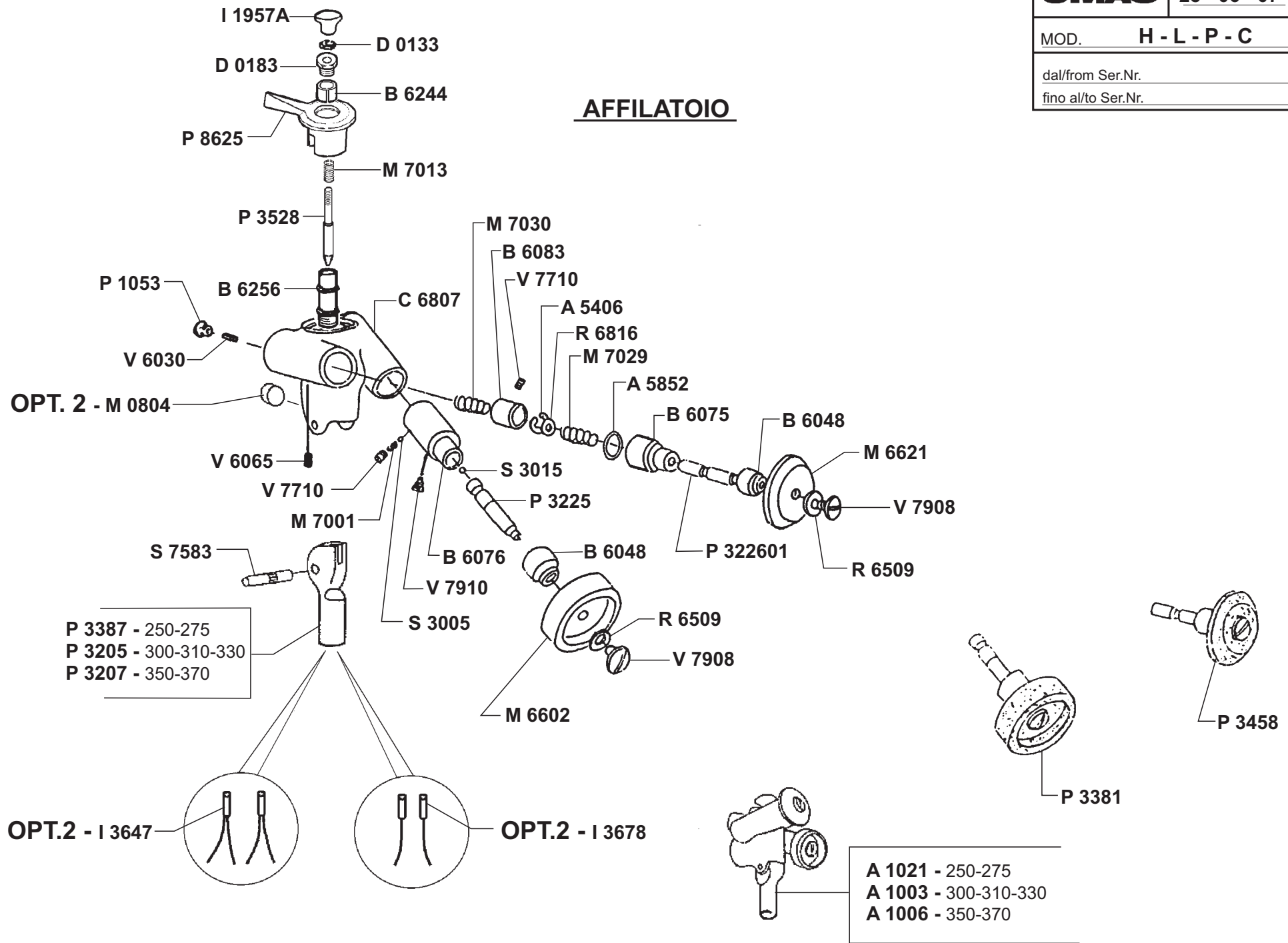

P 3387 - 250-275
 P 3205 - 300-310-330
 P 3207 - 350-370

A 1021 - 250-275
 A 1003 - 300-310-330
 A 1006 - 350-370

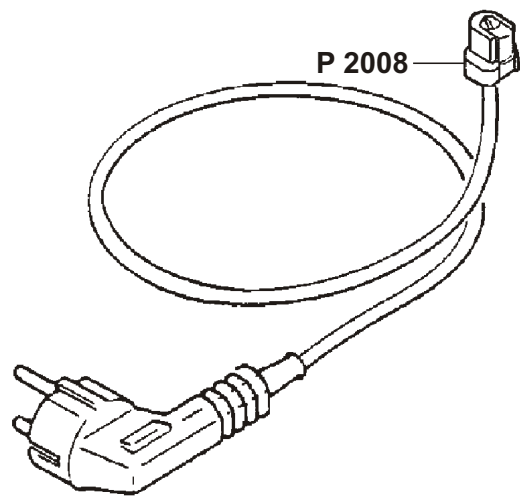
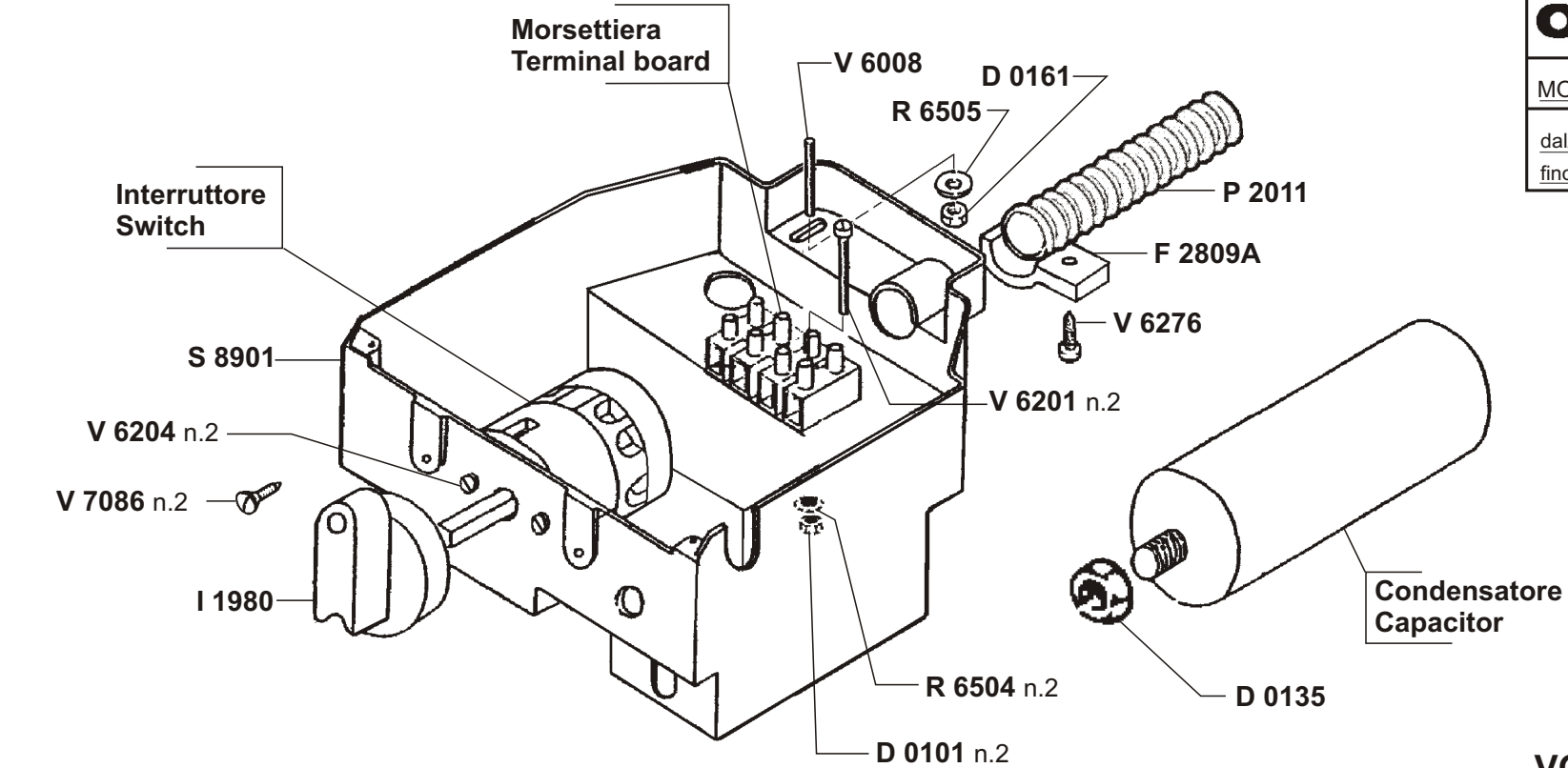

VOLT/Hz

	230/50	400/50	120/60	220/60
INTERRUTTORE SWITCH	I 3611	I 3610	I 3611	I 3611
CONDENSATORE CAPACITOR	C 5806A H-L-P250-300		C 5812 H-L-P250	C 5812
	C 5812 H-L-P350-370		C 5814 H-L-P300/350 H-L-370	C 5812
	C 5812 C300-370		C 5814	C 5812
MORSETTIERA TERMINAL BOARD	M 8005	M 8003	M 8005	M 8005
IMPIANTO ELETTRICO ASSIEMATO ELECTRICAL EQUIPMENT ASSY	I 1581 H-L-P250-300		I 1584	I 1584
	I 1583 H-L-P330-370-C	I 1580	I 1586 H-L-P300/350 H-L-370 - C	I 1583



S 3220 - 220/240V-50Hz-1
 S 3201 - 120V/60Hz-1

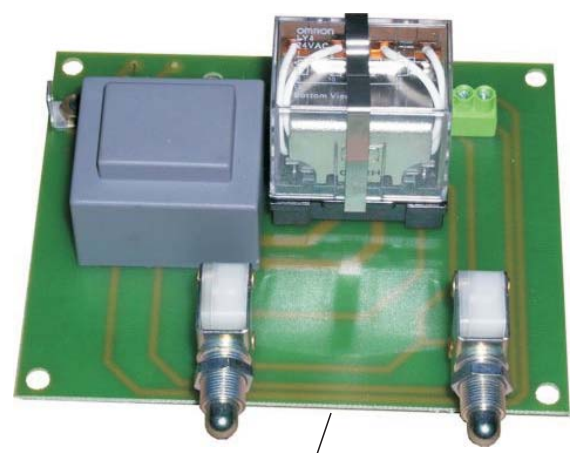

S 3240 - 220/380V-50Hz-3

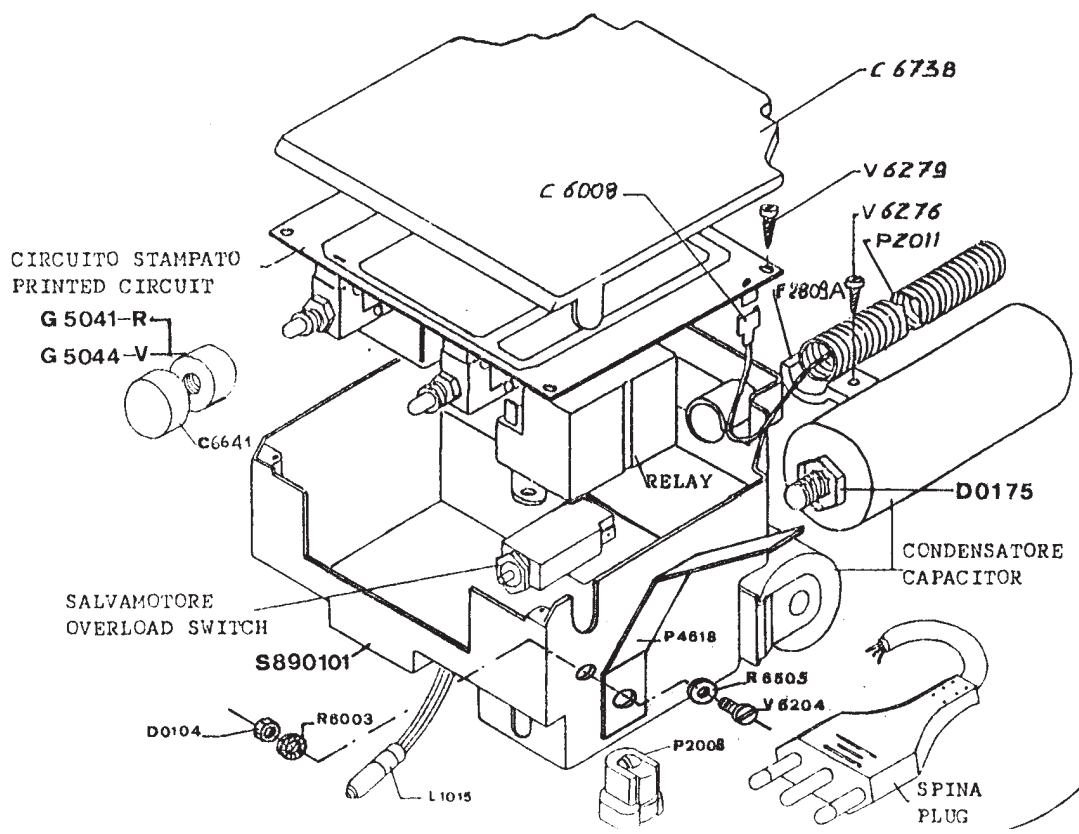

Imp.to elettrico

	VOLT/HZ							
	220/50	220 380	50	240/50	120/60	100 110	50	220/60
CONDENSATORE CAPACITOR	C 5832			C 5832	C 5880	C 5832		C 5832
SALVAMOTORE OVERLOAD SWITCH	I 3691			I 3691	I 3692			
CIRCUITO STAMPATO PRINTED CIRCUIT	S3220	S3240		S3220	S3201			
SCATOLA ASSIEMATA BOX ASSY	I 1624	I 1625		I 1624	I 1623			

TRASMISSIONEMOD. **T 8024**dal/from Ser.Nr. _____
fino al/to Ser.Nr. _____