

台灣 FARGO 輝豪牌
壓麵機

MODEL: CE-564R

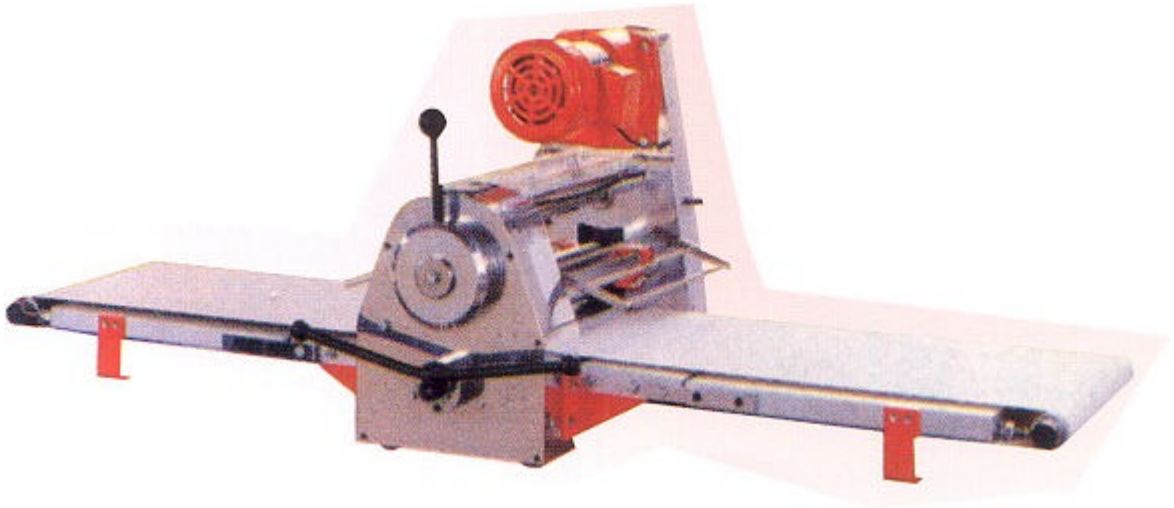

Operation Manual and Parts List
操作手冊及零件圖

What needs to be done before putting machine into operation?

1. After unpacking check whether all machine parts are there.
2. Examine machine and conveyor belts for any damage caused in transit.
3. Assemble the machine as follows:
 - Attach the tables (as per instructions on page 2)
 - Screw on telescopic rests and fasten screws firmly on underframe box
 - Check whether the top and bottom scrapers are correctly attached (see page 3)
 - Load the conveyor belts at the end of the table and attach dough catching troughs
 - Fit the plexiglass flour box
 - Have the machine connected by an electrician. Please follow the connecting diagram! Most Important: as the machine has in-built contactors, a neutral conductor is required. It is particularly important to ensure that when right foot-pedal is depressed the conveyor belts operate to the right and that they operate to the left when the left pedal is depressed. The phase sequence set-up must be strictly observed. If the machine is connected to a different power outlet, check immediately that the conveyor belts are operating in the prescribed direction.
 - Check the correct functioning of the protective grille - when the grille on the feed side is raised, the machine should cut out immediately.

No liability will be admitted for any damage or accidents that may be incurred through non-observance of this instruction.

TECHNICAL INSTRUCTIONS

MACHINE HEAD

1. SETTING ROLLER CLEARANCES

- a) Depress locking lever on handle of ROLLER ADJUSTMENT LEVER
- b) Turn ROLLER ADJUSTMENT LEVER to alter position of top pressure roller
- c) The SCALE DIAL indicates the value of the roller clearance setting.

2. DOUGH THICKNESS STOP CONTROL

- a) Set the ADJUSTMENT LEVER to the desired thickness
- b) Undo the KNURLED SCREW and move the sliding block till it comes up against the lever
- c) Tighten up the KNURLED SCREW.

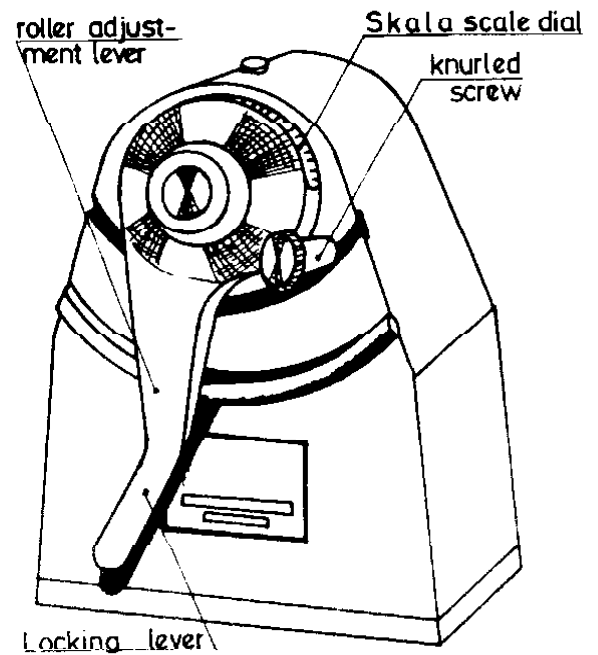

3. ATTACHING AND DETACHING OF THE MACHINE TABLES

3.1 Detaching machine tables

Before removing the machine tables always disconnect the machine at the mains.

- a) Detach the telescopic rests or table support brackets
- b) Press table back against spring-mounted conical bolt (see sketch)
- c) Tilt table upwards at front end and remove.

3.2 Attaching machine tables

- a) Press table against the conical bolt on the roller mounting till the CONE on the opposite side of the machine engages
- b) The DRIVING LUG must catch in the coupling bolt
- c) Attach the two telescopic rests or table support brackets and screw tight.

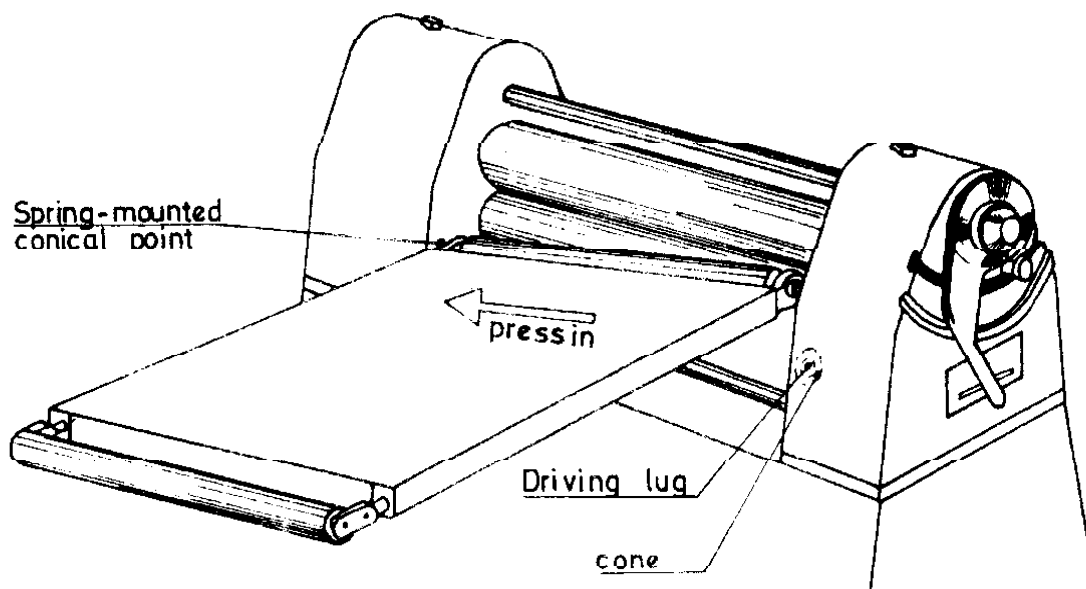

4. ATTACHING AND DETACHING THE SCRAPERS

4.1 Attaching top scrapers (angle scraper)

- a) Place SCRAPER on top pressure roller
- b) Pull out the spring-mounted RETAINING LEVERS far enough to allow angle scraper to slide underneath
- c) Position RETAINING LEVERS to engage the SCRAPER

4.2 Detaching top scraper

Lift up RETAINING LEVERS to allow SCRAPER to come away.

4.3 Attaching bottom scraper

- a) Place the T-SCRAPER with the hooks pointing downwards in space between pressure and conveyor rollers
- b) Push down T-irons as far as they will go into the lateral guides
- c) Affix spring-mounted rods under rolling table into the HOOKS.

4.4 Detaching bottom scraper

Reverse procedure described at 4.3

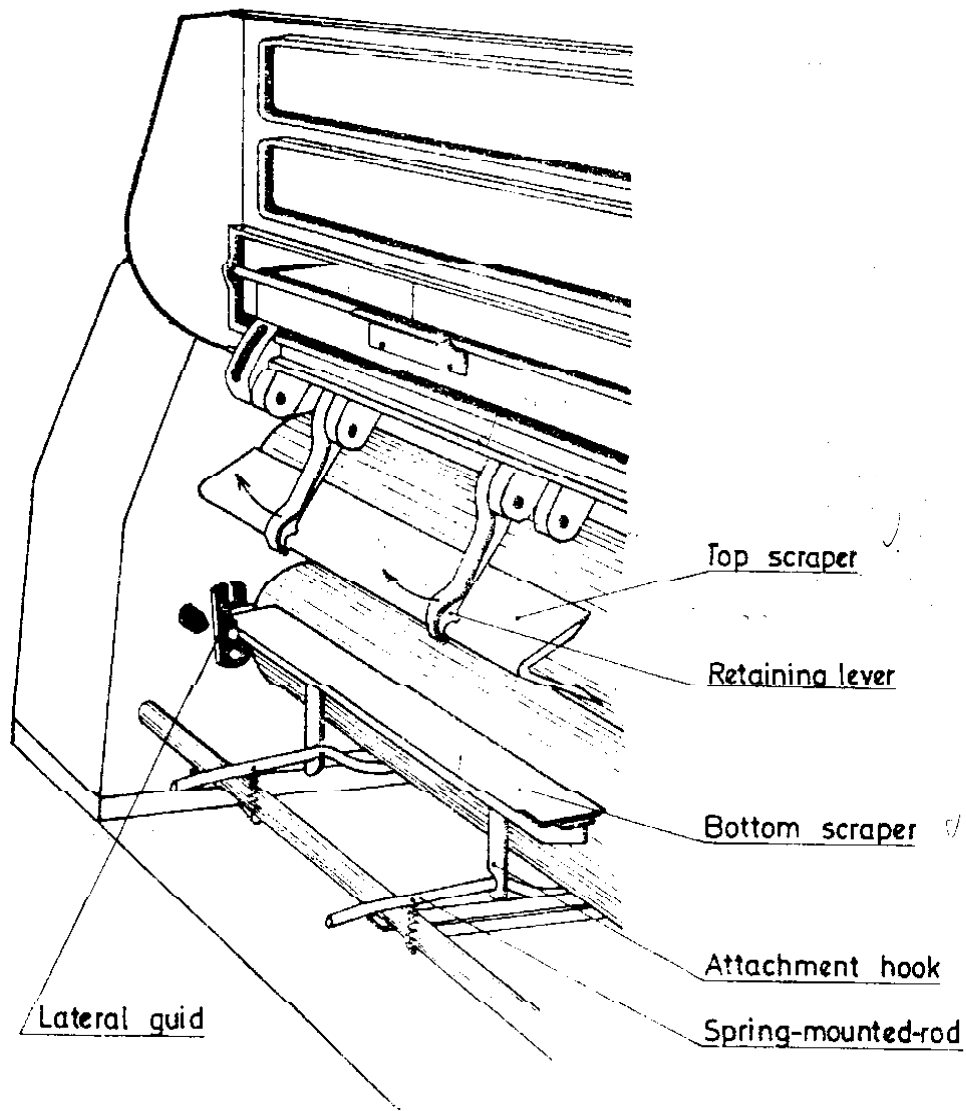

5. PROTECTIVE GRILLE

a) Raising

Lift up the PROTECTIVE GRILLE and press against the FLOUR BOX until the chromiumplated BAR engages in the SPRING CATCH.

b) Lowering

Take hold of the PROTECTIVE GRILLE by the top bar and lower down.

Take care that the sides of the grille do not come off!

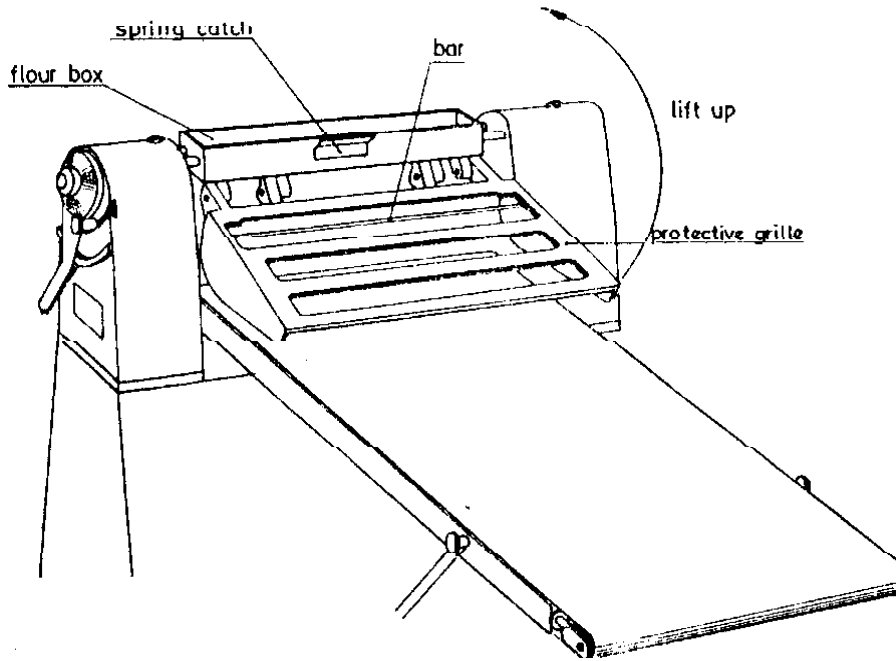

6. HAND ROLLER

The sheeted dough is wound up on the HAND ROLLER to be taken to the worktable.

6.1 Winding on the sheeted dough

- Raise ROLLER MOUNTINGS into upright position
- Place HAND ROLLER in the ROLLER MOUNTINGS (see sketch)
- Operate machine in the direction of the arrow
- Press the beginning of the dough strip onto the HAND ROLLER
- Let dough wind onto the roller
- Leave the dough after winding in the ROLLER MOUNTINGS or take away for further treatment

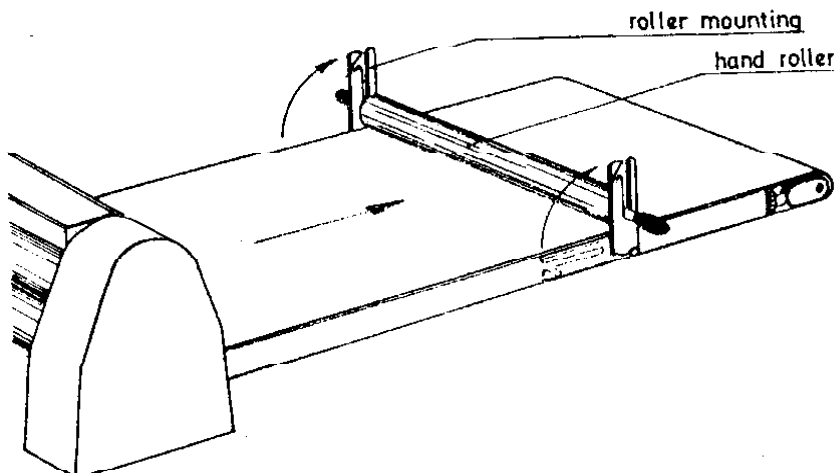

MAINTENANCE

If you have your machine regularly and properly serviced, it will always remain in good working order. Please order spare parts from our after sales service. You can then be sure that you will be getting parts of our own manufacture.

1. DISMANTLING CONVEYOR BELTS

- a) Take off the machine table
- b) Turn the two hand nuts to detension belt
- c) Remove belt from table

2. CLEANING CONVEYOR BELTS

Belts must only be brushed clean when they are dry.
NEVER clean them when they are still wet.

3. REGULATING TENSION OF CONVEYOR BELTS

Before operating the machine always see that the belt tension is properly regulated by appropriate adjustment of the hand nuts.

- a) Run the machine from left to right
- b) The belts must always move on a straight course. If a belt tends to run to one side, the tension on that side must be increased, or the hand nuts on the opposite side slackened off
- c) Run machine from right to left and regulate in the same way
- d) Do not load belts any more than is necessary for the conveyance of the dough

By setting and maintaining belts at the correct tension you will increase their service life.

4. CLEANING THE SCRAPERS

Remove top and bottom scrapers for cleaning

Rub the scrapers over with a damp cloth and replace.

IMPORTANT: Do not use a sharp or pointed instrument to scrape off bits of dough that have become hard.

5. LUBRICATION

The machine head is filled with a high-performance semifluid grease which will need to be changed after about 5 years of operating on the basis of an 8-hour day.

6. TENSIONING V-BELTS

6.1 Machine drive

- a) Unscrew cover on underframe box
- b) Loosen (1) hexagon screw
- c) Move down motor baseplate and motor
- d) Tighten (1) hexagon screw

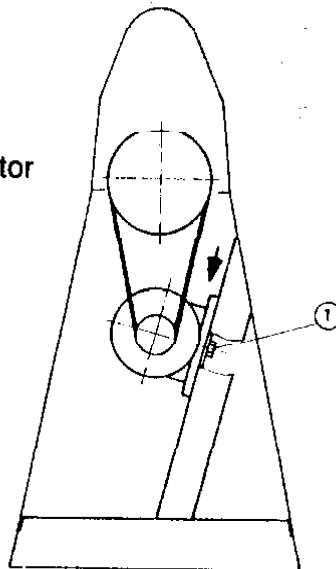

7. TENSIONING DRIVING CHAIN

IMPORTANT: after every one or two years of operation the chain should be checked for correct tensioning.

Any play in the driving chain can be verified by movement of the top roller with the hand.

If the roller turns more than a centimetre without any rotation on the part of the bottom roller the driving chain needs to be re-tensioned.

Driving chain can be tensioned from outside.

- a) Undo **CLAMPING SCREWS** (2 one above the other)
- b) Adjust the **CHAIN TENSIONER** with a screwdriver
- c) Tighten up the **CLAMPING SCREWS** again.

8. PARALLEL SETTING OF ROLLERS

After the driving chain has been tensioned it must be verified whether the top roller is in parallel with the bottom roller.

- a) Undo **CLAMPING SCREWS** on front of housing
- b) Turn eccentric bolt with a screwdriver till top roller is in parallel with the bottom one
- c) Tighten up **CLAMPING SCREWS** again.

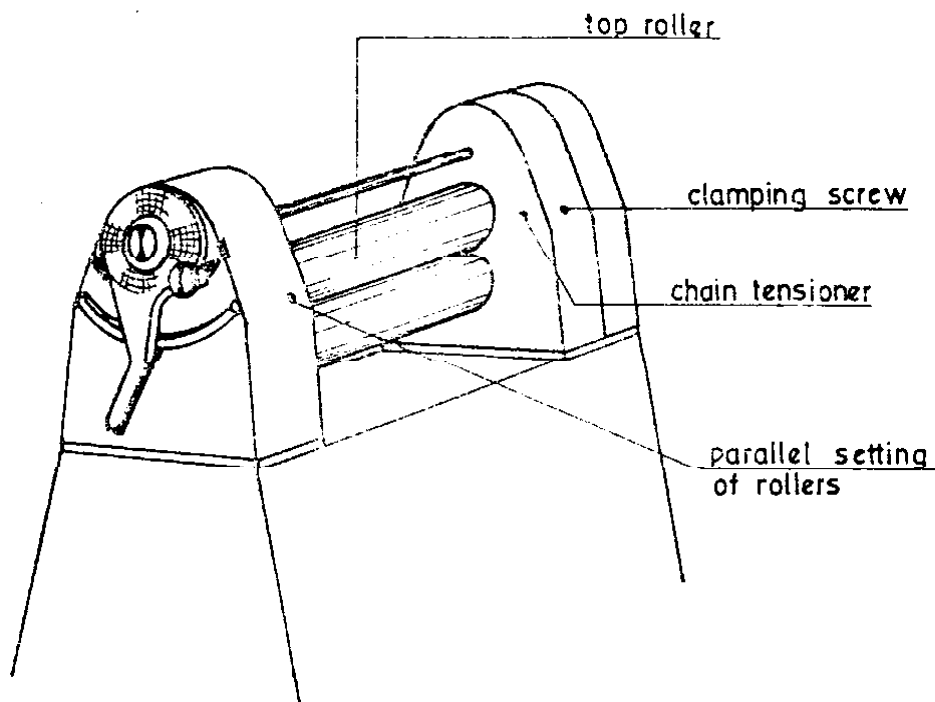

9. PRESSURE ROLLERS

If both rollers stop rotating this means that the brace connecting the sprocket wheel to the bottom roller has sheared away.

- a) Unscrew COVER and INNER COVER
- b) Clean out housing
- c) Drill out 4mm pin-hole to 5mm
- d) Insert strong brace-pin 5mm × 37mm, and in this insert another brace-pin 3mm × 37mm.

IMPORTANT: the drill-hole should on no account be more than 5mm in diameter, or the brace will shear away again.

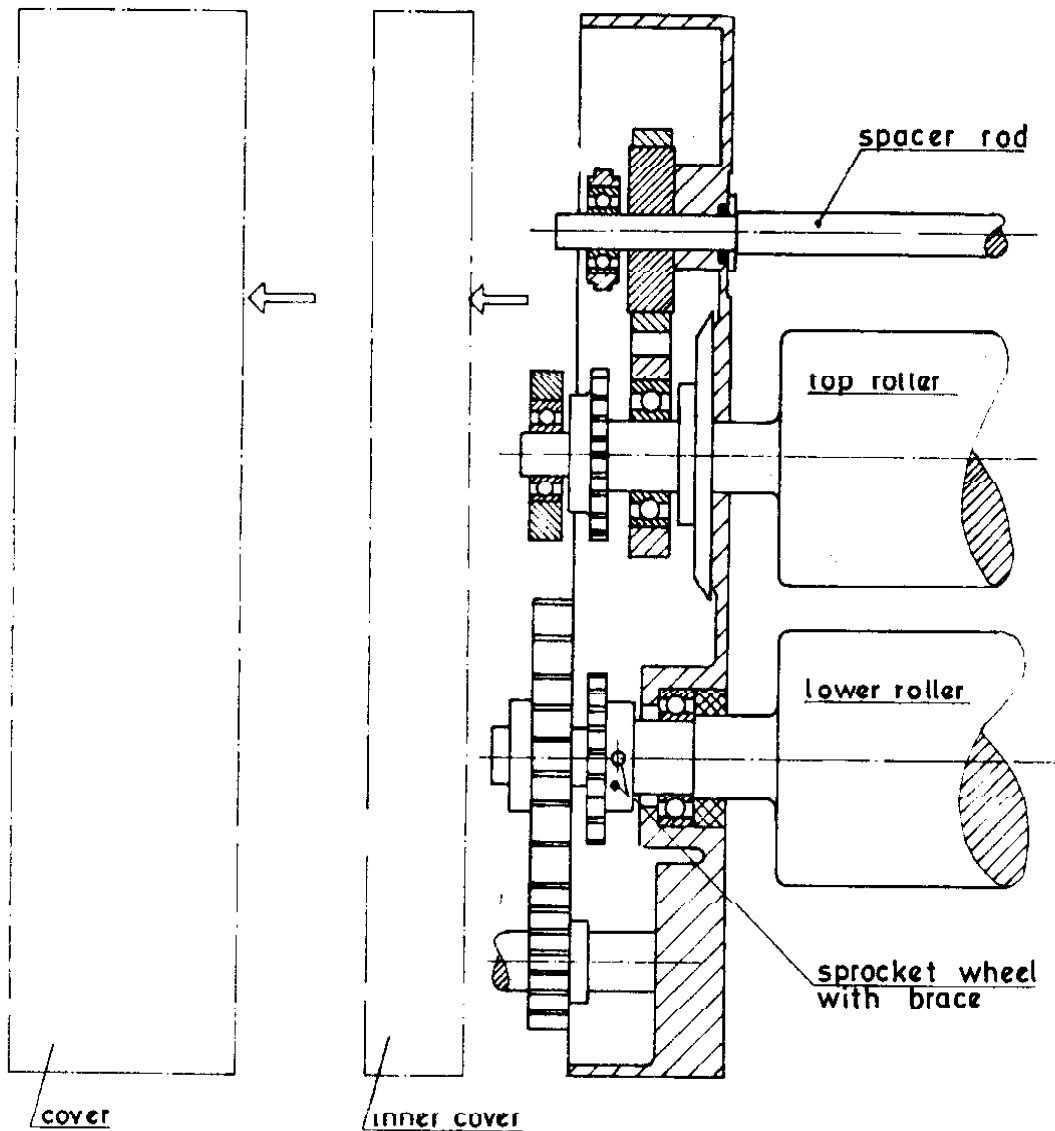

WHAT SHOULD I DO IF

1. The machine will not go
 - a) Check whether main switch is turned on
 - b) See that machine tables and protective grill are in working position
 - c) See that power plug is fully plugged in
 - d) Get an electrician to check plug and socket for loose connections
 - e) Remember that there must be a neutral conductor!
 - f) Check the fuses in the building

2. The machine keeps stopping intermittently
 - a) Look for defective contact in the plug
 - b) Check feeder cable for damage
 - c) Check on possibility of current fluctuations
 - d) Adjust limit switch for protective grille at back of machine housing

3. Machine will not pull dough trough
Re-tension V-belt from motor to the machine

4. Belts do not transport the dough anymore
Equalize tension in conveyor belts

5. Reverse conveyor belt no longer operates
 - a) Check first whether it has been switched on
 - b) Check V-belt and retension as required

6. Machine develops a hum
 - a) Have motor looked at by an electrician. It is very likely to be running only on two phases
 - b) Inspect the fuses in the bulding

ELECTRIC CONTROL DIAGRAM

unit list:

- F1 motor protector relay
- F2 fine fuse 1A
- K1 contactor
- K2 contactor
- S1 switch
- S2 switch
- S3 switch
- S4 switch
- S5 switch
- A1 amplifier
- M1 motor
- Q1 cam switch
- X1 plug connector
- X2 5-pole plug
- Y1/Y2 magnet

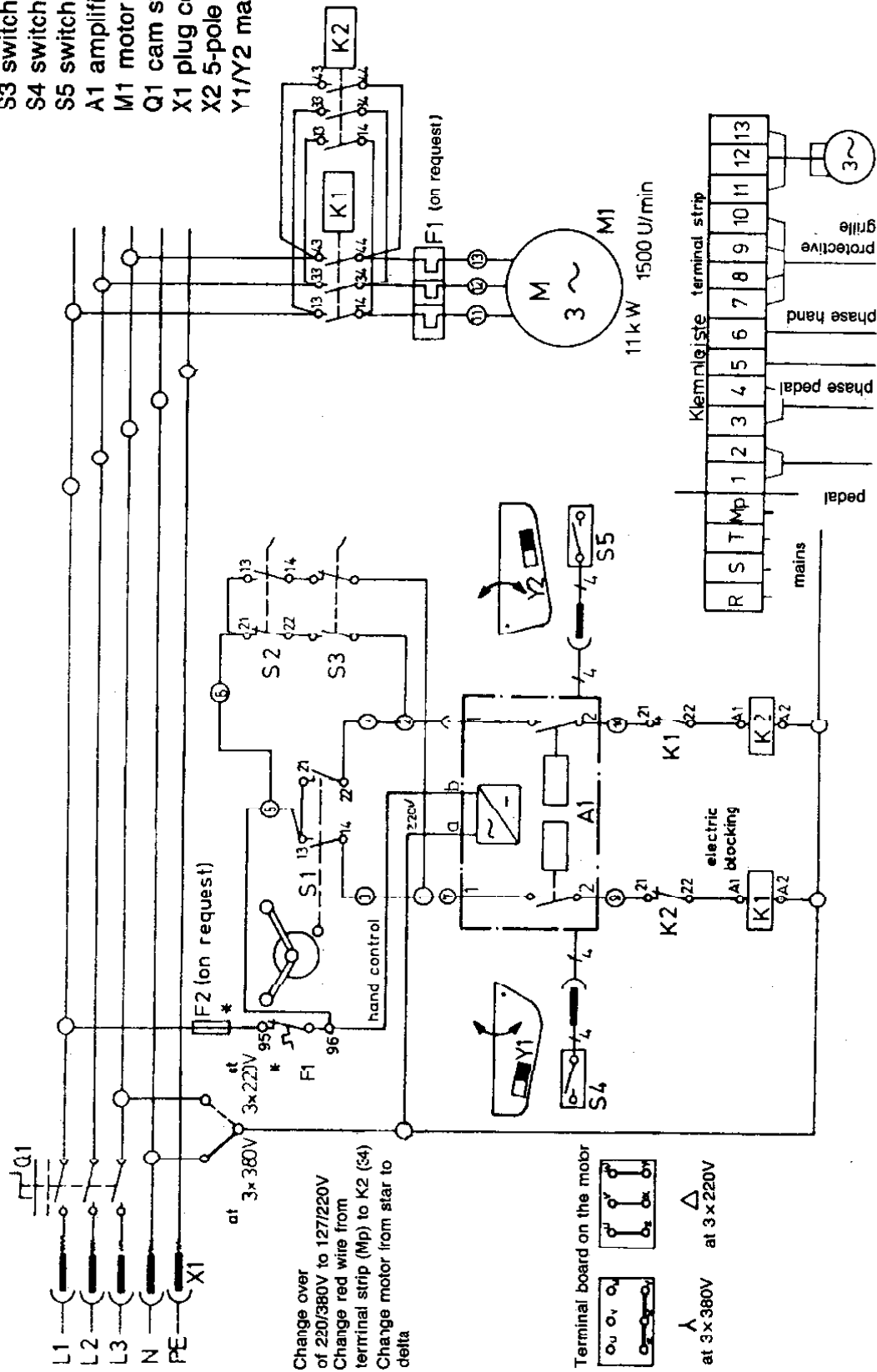

Search for defects and repair of electric of dough sheeting machines

1. Machine does not run at all

Check plug socket R, S, T and Mp (neutral conductor) Switch on, check on terminal R, S, T and Mp (neutral conductor)

2. Check right-handed run

Click hand-lever into position "Right-handed run".

Meter from Mp (n.c.) to terminal 6, then meter from Mp (n.c.) to terminal 3.

Meter from Mp (neutral c.) to terminal 9. If there is no tension, check protective grille and table switch. In order to do so, unscrew cover of the head on the opposite side. If they are alright, meter from terminal 41 of contactor C2 to Mp (neutral c.). If there is no tension on terminal 42, exchange contactor C2.

If there is tension on terminal 42 of contactor C2, meter from contactor connection C1a to C1b.

3. Check left-handed run

Click hand lever in position "left handed run".

Meter from Mp (neutral c.) to terminal 6, then from Mp (n.c.) to terminal 4.

Meter from Mp (neutral c.) to terminal 10. If there is no tension, check protective grille and table switch. In order to do so, unscrew cover of the head on the opposite side.

If these are alright meter from terminal 41 of contactor C1 to Mp (neutral c), then meter from terminal 42 to Mp (n.c.).

If there is tension on terminal 42 of C1, then meter contactor connection C2a to C2b.

If there is 220V, exchange contactor C1.

4. Check pedal switch

If hand switch is alright, check pedal switch as follows:

Meter from Mp (n.c.) to terminal 5.

Then operate right pedal switch.

Now power must be on terminal 2, at the left foot-operated switch on terminal 1.

If this is not the case remove cover at the bottom of the machine and check final switch.

5. Motor is purring

Meter from terminal 11 to terminal 12 and 13. In both cases there must be right voltage.

If this is not the case meter from contactor C1 terminal 14 to terminal 24 and 34.

If there are 380 VWs in each case check whether motor is purring in right-handed run or left-handed run. Exchange contactor accordingly.

If there are right voltage on terminal 11, 12, 13 check motor terminal strip whether right voltage are at the motor. If this is the case and the motor keeps purring then exchange the motor.

n.c. = neutral conductor